

WHOLE STRUCTURE

AIR SUSPENSION

CENTRIFUGAL BLOWER

The whole machine is highly integrated

Small size, light weight, special structure design, easy installation, portable disassembly and assembly.

PLC electronic control system

- Adopt international brand PLC, real-time monitoring system operation data and trajectory, multiple protection and early warning functions;
- Internet of things database management to set up a background service platform, and modular management of equipment energy efficiency.



High efficiency inverter

- Adopt well-known brand inverter, high stability and reliability;
- Provide miniaturization algorithm for high-speed rotation; Adjust the fan air volume through the frequency converter, the adjustable range is 450/o-IQQOfc
- Equipped with a backup capacitor inside, which can quickly and safely make the equipment slow down and stop in the event of a power failure.

Permanent magnet high-speed host

- The optimized design of PMSM permanent magnet synchronous motor rotates at high speed, the efficiency can reach more than 96%, and accurate speed control can be carried out through the frequency converter;
- Precision machining ternary flow impeller;
- Non-contact air suspension bearing;
- Two-stage air-cooled self-cooling method.

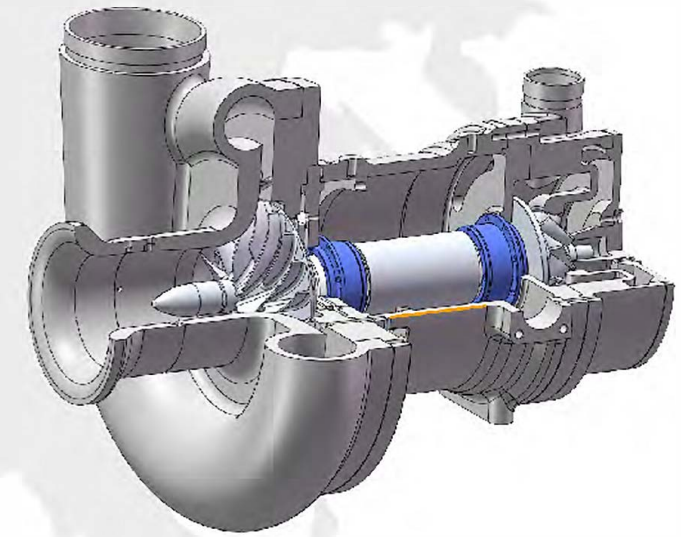

Intelligent operation panel

- Real-time monitoring of equipment operation on the touch screen;
- Intelligent remote control;
- With anti-surge protection function, it provides a variety of working modes;
- Automatic fault alarm, it is easy to analyze the cause of the fault.



COMPREHENSIVE ADVANTAGES

Energy efficient

- 30% energy saving compared with traditional Roots blower

Efficient Air Energy Management

- PLC control system + touch screen, real-time monitoring system operation
- Standard Internet of Things, component background service platform, control the operation anytime, anywhere

Low maintenance cost

- Semi-permanent design under 20 years, no iterative troubles
- 100% oil-free air-floating bearing system to avoid secondary pollution, no need for regular maintenance and replacement of bearings

Easy to install

- The whole machine is highly integrated, small in size and light in weight
- No foundation or anchor bolts required

Air Suspension Centrifugal Blower

TURBO BLOWER

- Power: 7.5-300kW
- Pressure: 40-120kPa



Low noise no vibration



Energysaving and environmental protection



Intelligent remote control



Convenient disassembly and assembly



PARAMETER SELECTION

Technical data sheet XLCB10-XLCB400(60/80/100/120kPa)

Model	XLCB 10	XLCB 20	XLCB 30	XLCB 40	XLCB 50	XLCB 100	XLCB 150	XLCB 200	XLCB 250	XLCB 300	XLCB 400	XLCB 100	XLCB 150	XLCB 200	XLCB 300	XLCB 400
Motor power	kW	7.5	15	22	30	37	45	55	75	90	110	150	185	220	300	
Compression level		Single stage	Single stage	Single stage	Single stage	Single stage	Single stage	Single stage	Single stage	Single stage	Single stage	Single stage	Single stage	Single stage	Single stage	Single stage
Exhaust pressure	kPa	Flow rate(m ³ /min)														
60		6.5	13	20	27	34	42	51	69	82	104	140	158	208	269	
80		—	10	17	23	28	34	42	55	70	83	108	133	162	214	
100		—	—	—	—	22	23	34	45	53	64	86	104	132	170	
120		—	—	—	—	—	—	—	39	47	58	77	—	—	—	
Cooling method		Air cooling														
Driving mode		Integrated direct drive														
LxWxH (mm)	L	660	660	700	700	700	850	850	850	850	1250	1250	1250	1300	1300	
	W	1080	1080	1600	1600	1600	1775	1775	1775	1775	1975	1975	1975	2475	2475	
	H	910	910	1340	1340	1340	1520	1520	1520	1520	1670	1670	1880	2200	2200	
N.W	kg	310	310	430	470	470	620	620	630	650	1150	1150	1350	2150	2200	
Outlet pipe diameter		DN65	DN65	DN150	DN150	DN150	DN200	DN200	DN200	DN200	DN300	DN300	DN300	DN400	DN400	

PARAMETER SELECTION

Technical data sheet XLCB10-XLCB400(40kPa)

Model		XLCB 10	XLCB 20	XLCB 30	XLCB 40	XLCB 50	XLCB 60	XLCB 75	XLCB 100	XLCB 125	XLCB 150	XLCB 200	XLCB 250	XLCB 300	XLCB 400
Motor power	kW	7.5	15	22	30	37	45	55	75	90	110	150	185	220	300
Compression level		Single stage	Single stage	Single stage	Single stage	Single stage	Single stage	Single stage	Single stage	Single stage	Single stage	Single stage	Single stage	Single stage	Single stage
Exhaust pressure	kPa	Flow rate(m ³ /min)													
	40	10	20	30	40	50	60	75	100	125	150	200	250	300	400
Cooling method		Air cooling													
Driving mode		Integrated direct drive													
LxWxH (mm)	L	660	660	700	700	850	850	1250	1250	1250	1250	1300	1300	1300	1300
	W	1080	1080	1600	1600	1775	1775	1975	1975	1975	1975	2475	2475	2475	2475
	H	910	910	1340	1340	1520	1520	1670	1670	1880	1880	2200	2200	2200	2200
N.W	kg	310	310	470	470	620	620	1150	1150	1350	1350	2150	2150	2200	2200
Outlet pipe diameter		DN65	DN150	DN150	DN150	DN200	DN200	DN200	DN300	DN300	DN300	DN400	DN400	DN400	DN400

INSTALLATION DIAGRAM

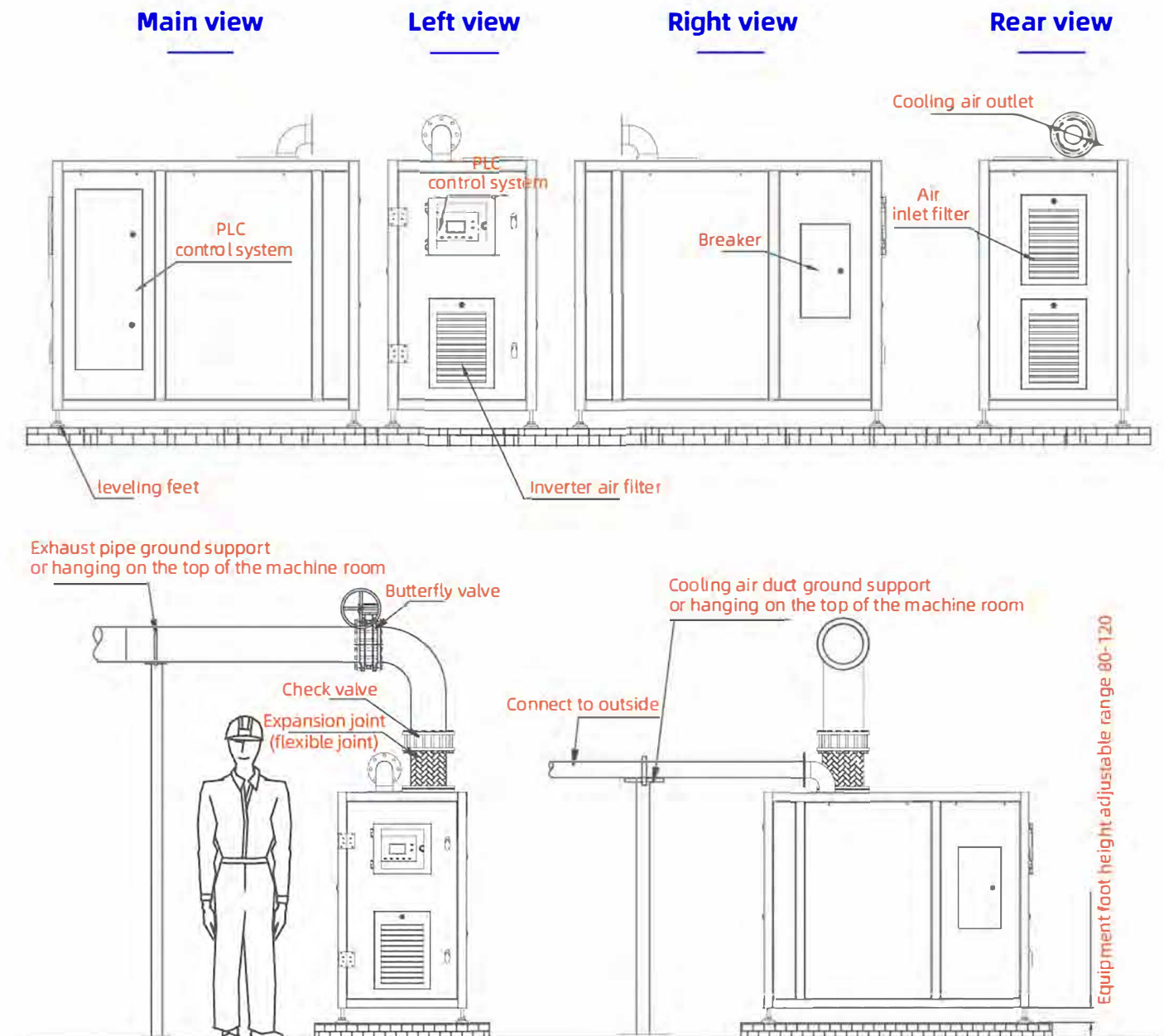

The standard configuration

- Centrifugal blower host
- Chassis (considering the sound insulation function)
- Inverter - Inverter
- Local control system
- Vent valve

Select configuration

- Temperature and Pressure Sensors
- Inlet Filters
- Outlet check valve
- Outlet elastic joint
- Overhaul manual butterfly valve

COMPREHENSIVE ADVANTAGES

Energy efficient

- 30% energy saving compared with traditional Roots blower

Efficient Air Energy Management

-PLC control system + touch screen, real-time monitoring system operation
-Standard Internet of Things, component background service platform, control the operation anytime, anywhere

Low maintenance cost

-Semi-permanent design under 20 years, no iterative troubles
-100% oil-free air-floating bearing system to avoid secondary pollution, no need for regular maintenance and replacement of bearings

Easy to install

- The whole machine is highly integrated, small in size and light in weight
- No foundation or anchor bolts required

Air Suspension Centrifugal Blower

TURBO BLOWER

- Power:7.5-37kW
- Pressure:40-100kPa



Low noise no vibration



Energy saving and environmental protection



Intelligent remote control



Convenient disassembly and assembly



PARAMETER SELECTION

Model		XLCB10-M	XLCB20-M	XLCB30-M	XLCB40-M	XLCB50-M
Motor power	kW	7.5	15	22	30	37
Exhaust pressure	kPa	Flow rate(m ³ /min)				
40		8.5	15	23	30	40
60		6.5	13	20	27	34
80		—	10	17	23	28
100		—	—	—	—	22
LxWxH (mm)	L	660	660	700	700	700
	W	1020	1020	1160	1160	1160
	H	780	780	860	860	860
N.W	kg	255	255	290	300	320
Outlet pipe diameter		DN65	DN65	DN100	DN100	DN100